

**Certified  
EXPLOSION  
PROOF**

Certified by ETL to meet UL standards for Class I, Div 1 and 2, Group D and Class II, Div 1 and 2, Group F & G.



**EXPLOSION PROOF SERIES**



Accessory Package, 151510DEX, Includes: Vacuum Hose: 1.5" x 10'; Urethane, Static Conductive,, Molded Carbon Impregnated Cuffs; Wand: 54", Aluminum Shaft, 2 Bends; Crevice Tool: 11", Aluminum Body; Round Brush: 3", Nylon Bristles, Static Conductive, Carbon Impregnated; Floor Brush: 14", Metal Body, Anti-Static Bristles; Reducer: 2" x 1.5"

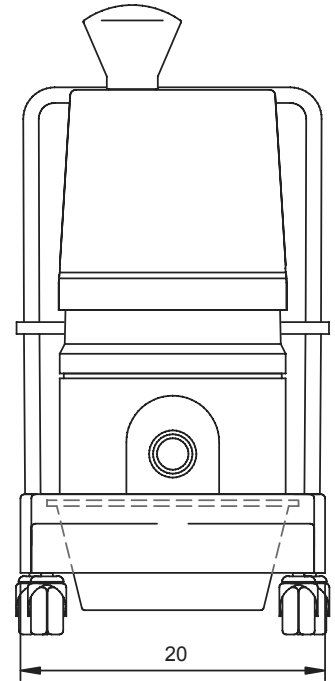
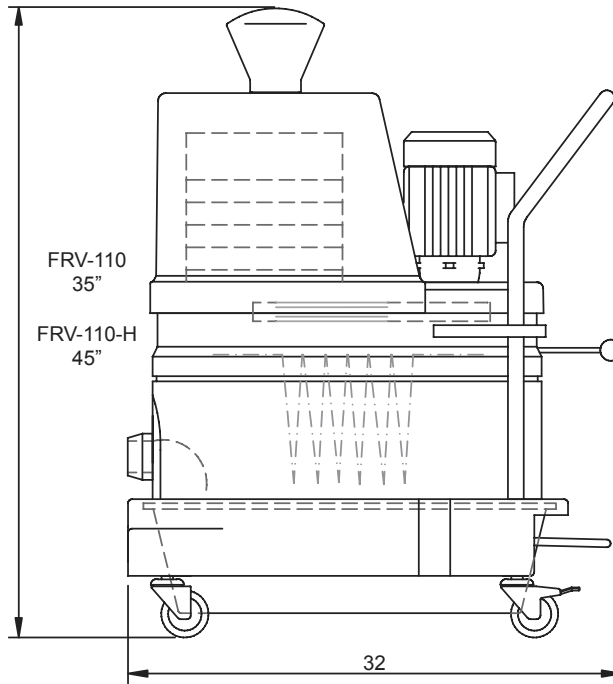

**FRV 110 Standard Specifications**

- DS1-EX1000 NRTL CERTIFIED EXPLOSION PROOF Motor & Switch, Class I, Class II
- 1.5 HP Motor, 110 Volt, 16 Amp, Single Phase, 60 Hz
- 13 ft<sup>2</sup> MicroClean BVSC Filter, Manual Shaker System
- 40 ft<sup>2</sup> HEPA Filter with Minihelic (optional)
- 2" (50mm) Inlet Connection with Bronze Cast Deflector
- Multi-Stage Centrifugal High Performance Turbine w/Relief Valve
- 9 Gallon, Foot Lever Actuated Dustpan
- Counterbalanced Base with 3" Heavy Duty Conductive Casters
- Compression Cast Composite Modular Housing
- Carbon Impregnated, Anti-Static 10<sup>-6</sup> Ohms



**Base Price<sup>1</sup>: FRV 110 - Call for Pricing**

ADDER	DESCRIPTION
D	Explosion Proof HEPA Module <sup>1</sup>
24000	Static Conductive Disposable Dustpan Liner with Lid <sup>ACC1</sup>
15600HDEX	Overhead Cleaning Accessory Kit <sup>PKG</sup>
-25	Optional - increase hose length to 25' <sup>HOS2</sup>
302120-EX	Extended Caster Frame Assembly w/Antistatic Casters <sup>2</sup>
34878	Retractable Grounding Reel w/Stainless Steel Clamp <sup>2</sup>

<sup>1</sup>EX, <sup>2</sup>ADD