

PremAire[®] System

SECOND STAGE REGULATOR



For More Information: Call (1-800-MSA-2222) or Visit Our Website at (www.MSAnet.com)



Be Sure.
Choose MSA.

MINE SAFETY APPLIANCES COMPANY
PITTSBURGH, PENNSYLVANIA, U.S.A. 15230

Firehawk Second Stage Regulator Assembly

Second Stage w/Hose Ass'y Push-To-Connect

- 10033170 24" Front
- 10033171 42" Rear
- 10033172 Snap-Tite 42"
- 10033173 Snap-Tite 24"

Second Stage w/Hose Ass'y Slide

- 10033116 24" Front
- 10033117 42" Rear
- 10033118 Snap-Tite 42"
- 10033119 Snap-Tite 24"

Item	Part No.	Description
1	697453	O-RING, FLUORSILICONE
2	634669	O-RING, SILICONE
3	10018540	DIAPHRAGM ASSEMBLY
4	10018547	UCLIP, (2 REQ'D)
5	10018622	RETAINER, SPRING (NOT USED WITH SOLID COVER)
6	10018774	KNOB, BYPASS
7	10018965	SPRING, QC, (2 REQ'D)
8	10018966	BODY, BYPASS
9	10018971	BYPASS INSERT ASSEMBLY
HOSE ASSEMBLY SECOND STAGE		
10	10033174	FRONT 24" SNAP-TITE
	10033175	REAR 42" SNAP-TITE
	10033177	FRONT 24"
	10033176	REAR 42"
11	10020784	SCREEN, BYPASS
12	10020931	SPRING, PD
13	10023509	O-RING, VITON (2 REQ'D)
14	10023580	O-RING, SILICONE (2 REQ'D)
15	10024111	QC BUTTON ASSEMBLY
16	10024112	SLIDEBUTTON ASSEMBLY
17	10030664	VALVE ASSEMBLY W/SHUTOFF
18	10026003	HOUSING, REGULATOR
19	10026139	COVER ASSEMBLY
19a	10047406	SOLID COVER
20	10031192	O-RING, SILICONE

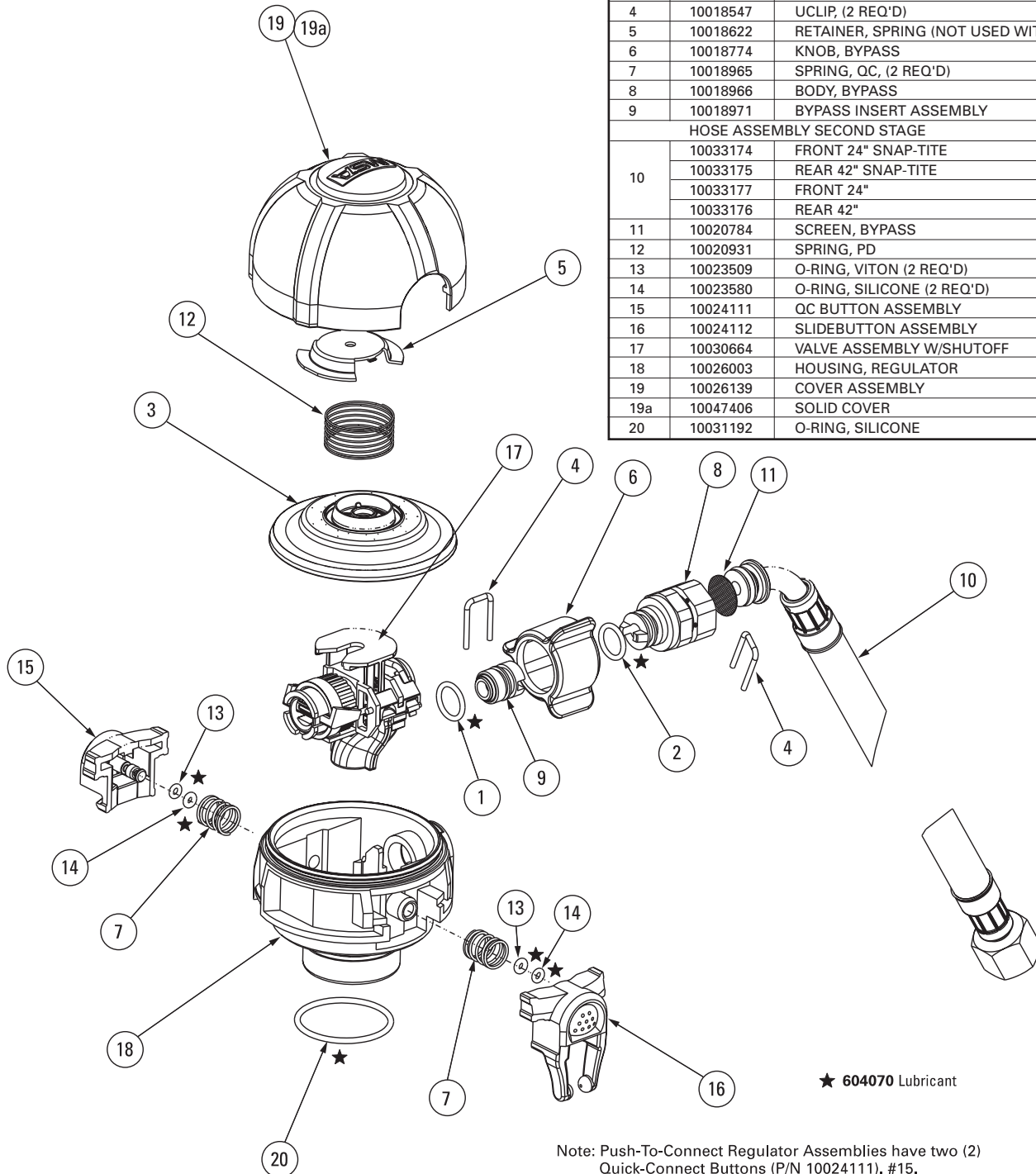

Note: Push-To-Connect Regulator Assemblies have two (2) Quick-Connect Buttons (P/N 10024111), #15.

Airhawk Second Stage Regulator Assembly

part number 10037656 Push-To-Connect

Item	P/N	Description
1	697453	O-Ring, Fluorsilicone
2	634669	O-Ring, Silicone
3	10018540	Diaphragm Assembly
4	10018547	Uclip, (2 Req'd)
5	10018622	Retainer, Spring (not used with solid cover)
6	10018774	Knob, Bypass
7	10018965	Spring, QC, (2 Req'd)
8	10018966	Body, Bypass
9	10018971	Bypass Insert Assembly
10	10020782	Hose Ass'y, 2nd Stg., Threaded
11	10020784	Screen, Bypass
12	10020931	Spring, PD
13	10023509	O-Ring, Viton (2 Req'd)
14	10037951	O-Ring (2 Req'd)
15	10024111	QC Button Assembly
16	10030664	Valve Assembly w/Shutoff
17	10026003	Housing, Regulator
18	10026139	Cover Assembly
18a	10047406	Solid Cover
19	10031192	O-Ring

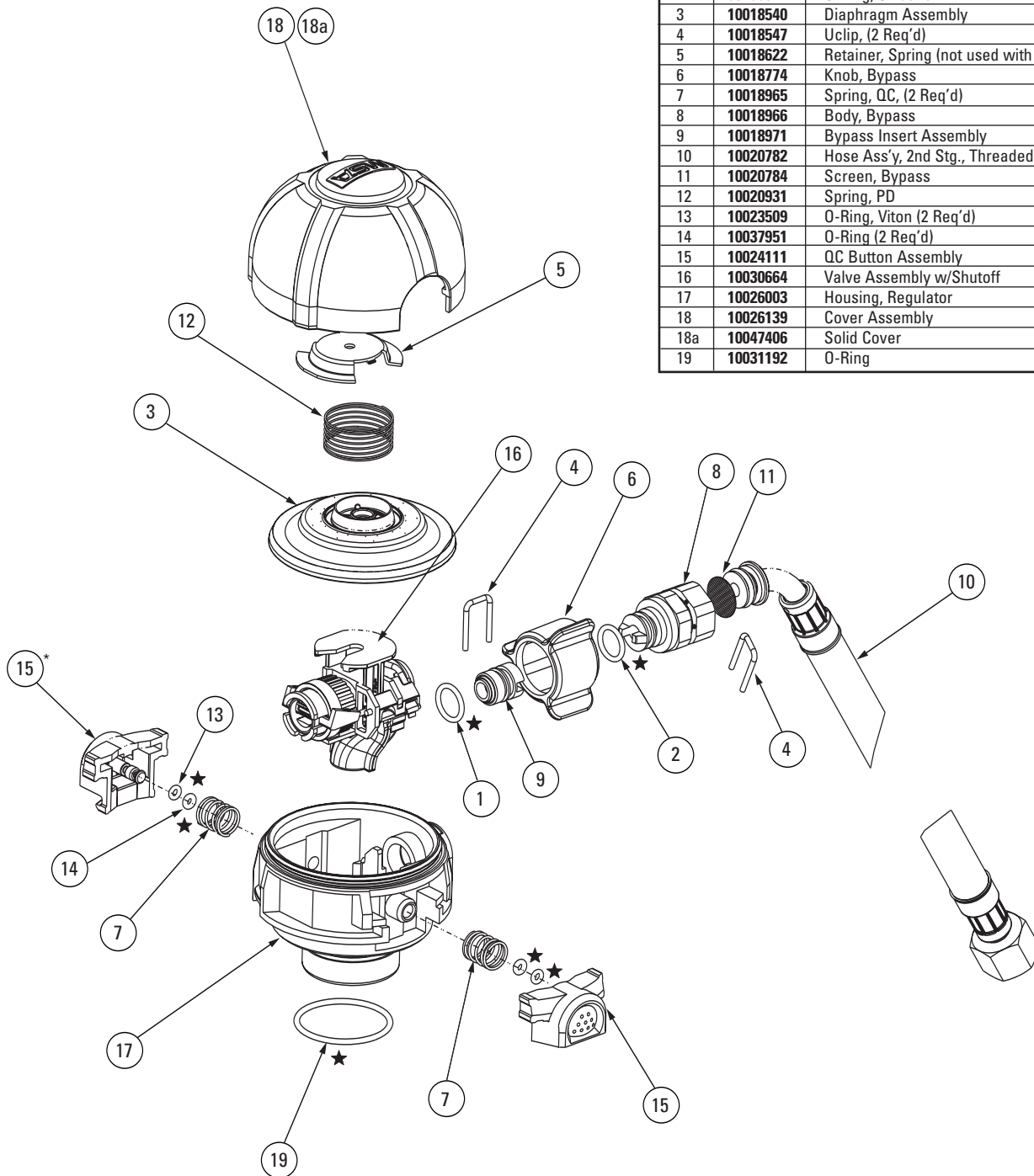

***Note:** Push-To-Connect Regulator Assemblies have two (2) Quick-Connect Buttons (P/N 10024111) #15

★ 604070 Lubricant

SECOND STAGE REGULATOR DISASSEMBLY

All repair procedures assume that the regulator is disassembled from the apparatus and facepiece. To do this:

- Be sure the cylinder valve is completely closed.
- Disconnect the regulator from the facepiece.
- Be sure nothing is blocking the regulator outlet. Crack the bypass valve to release any trapped air.
- If desired, disconnect the intermediate-pressure hose from the first stage regulator at the hose fitting using a 11/16" open-end wrench. Refer to the INTRODUCTION Tab of this Binder for General Notes and required tools.

Note: Refer to the appropriate illustrated parts lists for the apparatus being repaired.

REMOVING THE REGULATOR COVER, SPRING, AND SPRING RETAINER

1. Press and hold the housing buttons IN. Also, press the regulator housing retaining latches IN.



2. Pull firmly on the regulator cover to remove the cover, spring, and spring retainer from the regulator housing.



Note: Do not stretch the spring.

REMOVING THE SPRING AND SPRING RETAINER

1. Push the outside center (rubber) regulator cover IN.

Note: Do not pull the spring to remove the spring retainer.

2. Lift up on the spring retainer to remove it from the regulator cover.



REMOVING THE SPRING FROM THE SPRING RETAINER

1. Twist the spring clockwise to remove it from the spring retainer.

Note: Do not stretch the spring.

REMOVING THE DIAPHRAGM

1. Roll the diaphragm edges out of the regulator housing groove.
2. Slide the diaphragm away from the red bypass hand-wheel and slide the diaphragm off the valve fork.

DISASSEMBLING THE REGULATOR HOUSING O-RING

1. Remove the O-ring from regulator housing outlet. Be careful not to scratch the O-ring groove.

DISASSEMBLING THE BYPASS AND HOSE W/SWIVEL

1. Remove the regulator cover, spring, and spring retainer.

Note: DO NOT REMOVE THE DIAPHRAGM (option)

2. Use a small, flat-blade screwdriver to remove the U-clip from the regulator housing.



3. Remove the bypass and hose assembly from the regulator housing.

SECOND STAGE REGULATOR DISASSEMBLY

4. Remove the red bypass handwheel. Slide the handwheel back off the bypass body to reveal the U-clip in the bypass body.



5. Using a screwdriver, remove the U clip from the bypass body.



6. Remove the hose assembly by pulling the hose out of the bypass body.



7. Remove the hose assembly O-ring. Be careful not to scratch the O-ring groove.



8. Inspect the screen inside the bypass body. If dirty, all dirt and foreign matter must be removed before reusing the screen. If the screen is damaged, replace it, as follows:



- a. Insert a small screwdriver into the small hole side of the bypass body and push the screen out the large hole side of the bypass body.

INSPECTION FOR THE VALVE FORK FOR PROPER HEIGHT

- Press on the top of the valve fork assembly to ensure the valve fork assembly moves up and down freely.

Note: All calibrations will be performed with the bypass handwheel facing away and with the valve fork's slots facing in.

⚠ CAUTION

Ensure the U-clip holding the bypass and hose assembly in the regulator housing is not removed or lost.

Lever Height Gauge

Note: The raised cylinder with grooves represents acceptable lever height range for valve fork assembly.

SECOND STAGE REGULATOR REASSEMBLY

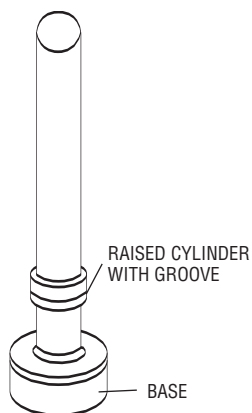

INSPECTION/ADJUSTMENT

- Place the large base of the Lever Height Gauge on the flat area of the valve assembly body under the valve fork assembly.
- Insert the Lever Height Gauge between the fork's slots of the valve fork assembly. Slide Lever Height Gauge back until the Lever Height Gauge is centered on the valve fork assembly.

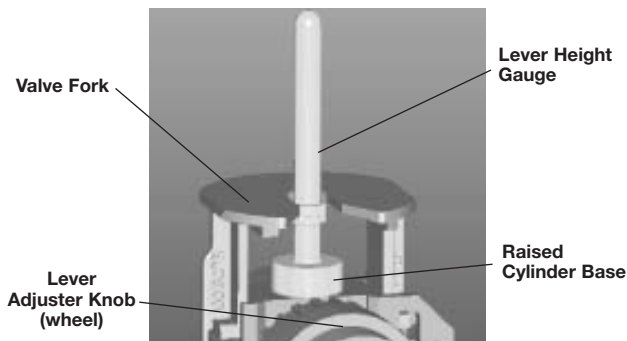

- The top surface of the valve fork should be anywhere along the raised cylinder surface of the Lever Height Gauge. Do not touch or exert pressure on the valve fork for this measurement.
- Then, press on the top of the valve fork assembly to ensure the valve fork assembly moves up and down freely.

NORMAL VALVE FORK HEIGHT RANGE

The required valve fork height range corresponds to the top surface of the valve fork at any position along the raised cylinder.

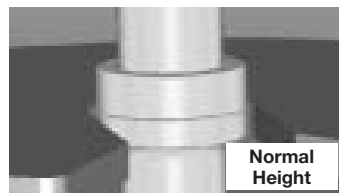

MAXIMUM VALVE FORK ALLOWABLE HEIGHT

The maximum valve fork allowable height corresponds to the valve fork top surface being even with the top edge of the raised cylinder.

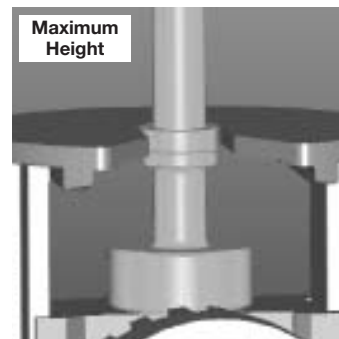

MINIMUM VALVE FORK ALLOWABLE HEIGHT

The minimum valve fork allowable height corresponds to the valve fork top surface being even with the bottom edge of the raised cylinder.

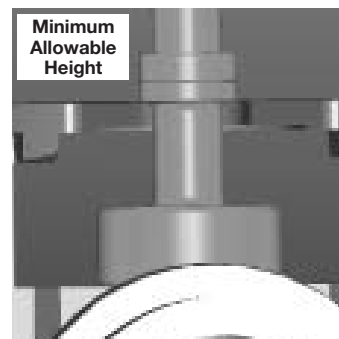

SECOND STAGE REGULATOR REASSEMBLY

ADJUSTING THE VALVE FORK HEIGHT FOR PROPER PERFORMANCE

Note: All calibrations will be performed with the bypass handwheel facing away and with the valve fork's slots facing in. The regulator must be depressurized.

CAUTION

Ensure the U-clip holding the bypass and hose assembly in the regulator housing is not removed or lost.

ADJUSTMENT FOR VALVE FORK MAXIMUM RANGE

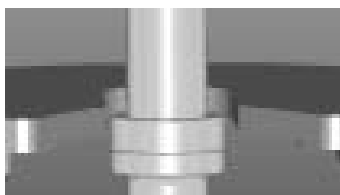

Note: Clockwise rotation of the lever adjuster knob (wheel) lowers the lever fork.

Note: All calibrations will be performed with the bypass handwheel facing away and with the valve fork's slots facing in.

CAUTION

Ensure the U-clip holding the bypass and hose assembly in the regulator housing is not removed or lost.

- Press on the top of the valve fork assembly to ensure the valve fork assembly moves up and down freely.
- Place a jeweler's screwdriver on the flats of the lever adjuster knob.
- Turn the lever adjuster knob (wheel) clockwise to lower the valve fork. Be certain adjuster knob clicks into position.
- The top surface of the valve fork should be along the grooved surface of the lever height gauge without exerting pressure on the valve fork assembly for normal valve fork height.

ADJUSTMENT FOR VALVE FORK MINIMUM RANGE

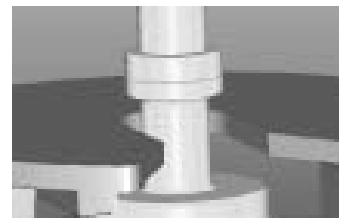

Lever Adjuster Knob (wheel)

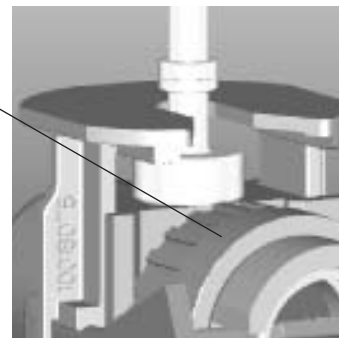

Note: Counter-clockwise rotation of lever adjuster knob (wheel) raises the lever fork.

Note: All calibrations will be performed with the bypass handwheel facing out.

CAUTION

Check that the U-clip holding bypass and hose assembly in the regulator housing is properly engaged. Pull on the bypass and hose assembly to ensure that the bypass and hose assembly are securely attached to the regulator housing with the U-clip.

- Press on the top of the valve fork assembly to ensure the valve fork assembly moves up and down freely.
- Place a jeweler's screwdriver on the flats of the lever adjuster knob.
- Turn the lever adjuster knob counter-clockwise to raise the valve fork. Be certain adjuster knob clicks into position.
- The top of the valve fork should be along the grooved surface of the Lever Height Gauge without exerting pressure on the valve fork assembly for normal valve fork height.
- Press on the top of the valve fork assembly to ensure the valve fork assembly moves up and down freely.

DISASSEMBLING THE VALVE ASSEMBLY

1. Remove the regulator cover, spring, and spring retainer.
2. Remove the diaphragm.
3. Remove the U-clip from the regulator housing.

Note: Use the bypass body as a tool to remove the bypass insert.

SECOND STAGE REGULATOR REASSEMBLY

4. Insert the bypass body into the regulator housing bypass port.

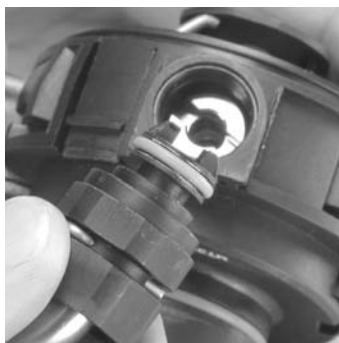

5. Turn the valve counter-clockwise to unthread the bypass insert from the valve.



6. Turn the regulator housing until the bypass insert drops out of the regulator housing.



7. To remove the valve, turn the regulator housing upside down, or lift the valve out of the regulator housing.

8. Replace all O-rings on the bypass insert and bypass body.

DISASSEMBLING THE REGULATOR HOUSING QC BUTTON AND SLIDE BUTTON

1. Remove the old O-rings. Be careful not to damage the O-ring seal area.



2. Pull on the buttons to remove them from the regulator housing. Be careful not to lose the spring.

REASSEMBLING THE DIAPHRAGM

1. Slide the diaphragm knob into the valve fork slot, then slide the diaphragm toward the red bypass handwheel.



2. Roll the diaphragm edges over the regulator housing groove.

Removing Spring from Spring Retainer

1. Twist spring (clockwise) out of spring retainer.

Note: Do not stretch the spring

Removing Diaphragm Assembly

1. Roll diaphragm edges out of regulator housing groove.
2. Slide diaphragm away from red bypass handwheel and slide the diaphragm off the valve fork.

SECOND STAGE REGULATOR REASSEMBLY

INSTALLATION

Installing Spring into the New Solid Regulator Cover

Note: New Solid Regulator Cover does not use a spring retainer.

1. Insert old spring into solid cover



- a. Sliding spring over finger, insert spring and finger into the inside of solid cover.
2. Attach last coil of spring over the cover's hooks

- a. Holding the spring centered in the solid cover with finger, insert thumb of other hand down along the inside of cover to the bottom of spring.



- b. Slip the last coil of spring over each of the three (3) molded hooks at the bottom of cover.

- c. Ensure that the last coil of the spring is engaged over each of the three (3) molded hooks.

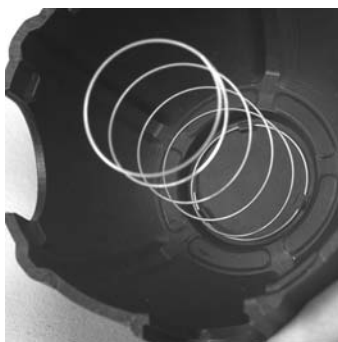

⚠ WARNING

Double check proper engagement of solid cover spring by lifting on spring to ensure that the spring is securely attached to the regulator cover. Do not stretch the spring. Failure to follow this warning may result in serious personal injury or death.

3. Push regulator cover and spring onto regulator housing.

⚠ WARNING

Double check proper engagement by lifting on regulator cover to ensure that the regulator cover is securely attached to the regulator housing. Failure to follow this warning may result in serious personal injury or death.

REASSEMBLING THE REGULATOR COVER

1. To install the spring in the retainer, press the spring's last coil over the retainer hooks.
2. Push the spring retainer over the regulator cover center stem.
3. Lift the spring retainer to check that the spring and retainer are engaged properly.
4. Push the regulator cover, spring, and spring retainer on the regulator housing.

⚠ CAUTION

Pull on the regulator cover to be sure the regulator cover and regulator housing are secure.

REASSEMBLING THE REGULATOR HOUSING O-RING

1. Apply a light film of Christo-Lube lubricant to the new O-ring.
2. Roll the new O-ring over the end of the regulator housing outlet and seat it into the O-ring groove. If the O-ring is not seated, it can cause an air leak.

REASSEMBLING THE BYPASS AND HOSE ASSEMBLY

1. Apply a light film of Christo-Lube lubricant to all O-rings.
2. Roll a new O-ring into the first groove of the bypass body.
3. Insert the new screen (if removed). Insert screen into the large hole (hose swivel) side of the bypass body. Be careful not to damage the screen. Make sure the screen is flat inside the body.

SECOND STAGE REGULATOR REASSEMBLY

4. Roll a new O-ring into the first groove of the hose swivel.



5. Insert the swivel into the bypass body.



Slide the U-clip through the bypass body. The U-clip should slide through the bypass body freely.



6. Slide the red bypass handwheel over the bypass body. The handwheel hex lines up with the handwheel.



7. Ensure that the hose with swivel moves freely.

8. Insert the bypass body and hose assembly into the regulator housing so that the bypass body tabs are lined up with the slots in the bypass insert.



9. Slide the U clip through the regulator housing. The U-clip should slide through the regulator housing freely.



REASSEMBLING THE VALVE ASSEMBLY

1. Insert the valve into the regulator housing -- valve fork slot facing up and away from the bypass port.
2. Push the valve into the regulator housing.

3. Insert the bypass insert into the bypass port -- slot facing out.



4. Use the bypass body to thread the bypass insert into the valve. Hand-tighten only.

Note: If the bypass insert does not thread into valve assembly easily, the valve assembly is not aligned in the regulator housing properly. Ensure that the valve assembly is fully seated in the regulator housing.

5. Insert the hose assembly and bypass body into the regulator housing.

SECOND STAGE REGULATOR REASSEMBLY

6. Insert the U-clip into the regulator housing.



7. Replace the diaphragm.
8. Replace the spring retainer, spring, and regulator cover.
9. Check the valve assembly calibration. (See Inspection for Valve Fork section.)
10. Flow-Test the SCBA (see the TESTER section of this Binder).

REASSEMBLING THE REGULATOR HOUSING QC BUTTON AND SLIDE BUTTONS

1. Apply a light film of Christo-Lube lubricant to the new O-rings.
2. Install new O-rings on the button's post.

Note: With the red bypass handwheel facing you and the cap facing up, the slide button is to the left and the housing button is to the right.

3. Install the spring. Align the buttons.
4. Push firmly on the buttons, install the post O-ring on the inside of the regulator housing.
5. Double-check proper engagement by pulling on the buttons to ensure that they are securely attached to the regulator.